

AVIO REI30

Laminato

Certificata EI30 secondo BS 476:22



Versione in laminato



Resistenza al fuoco 30 min.

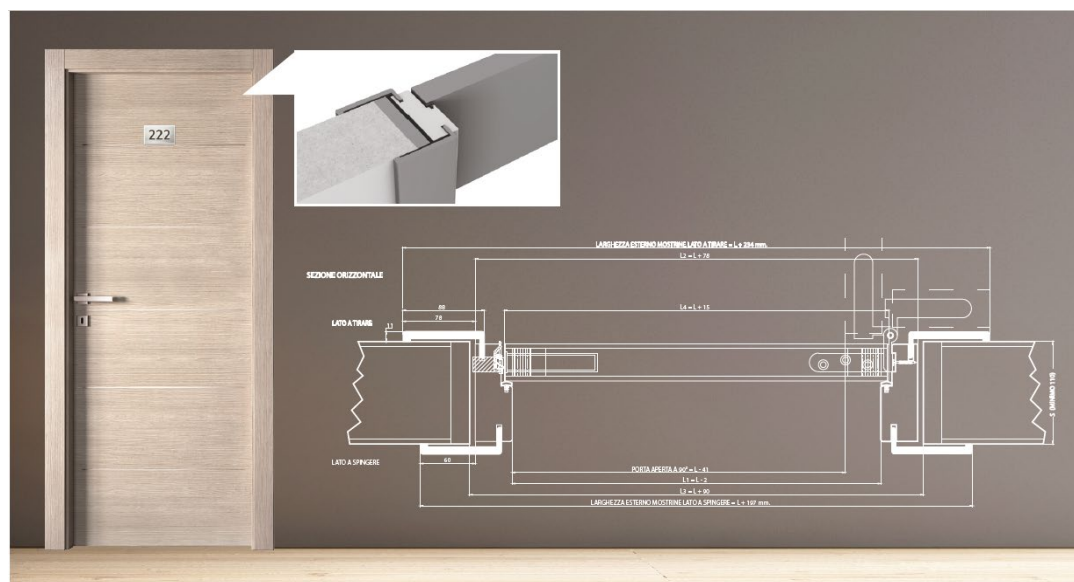

Standard Dimensions are:

Height 2000/2100 mm

Width 700/800/900 mm

Wall Thickness 120 mm

Minimum wall thickness 100mm

Other Dimensions are subject to surcharges – quotes available

Maximum Non Standard Heights to comply with BS Certification. ([Download the AVIO REI Fire Certificate here](#))

E1 – AVIO REI 30 PORTA SINGOLA

L \ H	2100	2150	2200	2250	2300
800	OK	OK	OK	NO	NO
850	OK	OK	OK	NO	NO
900	OK	OK	OK	NO	NO
950	NO	NO	NO	NO	NO
1000	NO	NO	NO	NO	NO

Designs Available

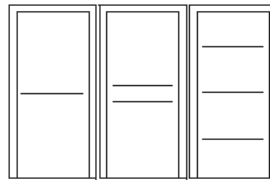
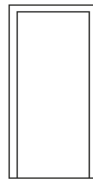

Finishes Available – Also Matt & Gloss RALS

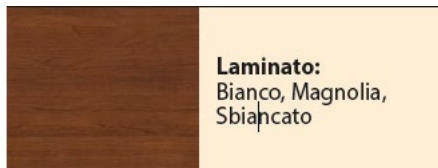

Request Samples & pdf section drawings– email to info@mooremoore.co.uk

Ironmongery - Option to Order without keyholes for internal door sets or for Entrance Doors with Key and Thumb Turn

(A)



Cerniera a bilico alta portata

(B)



Misura: 28+10+28



FORNITURA STD
3 chiavi



Accessories

Overhead Closers

C2 - CHIUDI PORTA AEREO A SLITTA E CHIUDI PORTA A BRACCIO A "V"

- disponibile nelle finiture cromo o ottone



Spyholes – Chrome/Brass

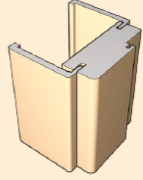
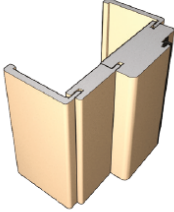

Frame Options for Non Standard Wall Thicknesses – Don't forget for tiled bathroom tiles to add the thickness of the tile and adhesive so that the architrave sits on top of the tiles for that perfect finish. Fillets available for half tiled walls etc.

<p>D4 – ALLARGAMENTO IMBOTTE SPESSORE MURO NON STANDARD:</p> <p>Per i muri di spessore da 12,5 a 14,5 cm, forniremo il telaio in un unico pezzo sa 12,5 cm</p> <p>Supplemento fisso + € 16,00 fisso</p>	
<p>D5 – Per i muri di spessore pari o superiore a 14,6 cm, forniremo il telaio da 10,5 mm con l'allargamento previsto.</p> <p>Supplemento al cm oltre i 10,5 cm + € 13,00 al cm</p>	 <p><i>Imbotte STD lato esterno</i></p>



Photograph Courtesy of Prestige Architecture & Design

Speak with Jenny or Steve Moore on 01752 547435 – Showroom Unit A1 Yelverton Business Park, Yelverton, Devon, PL20 6AR